

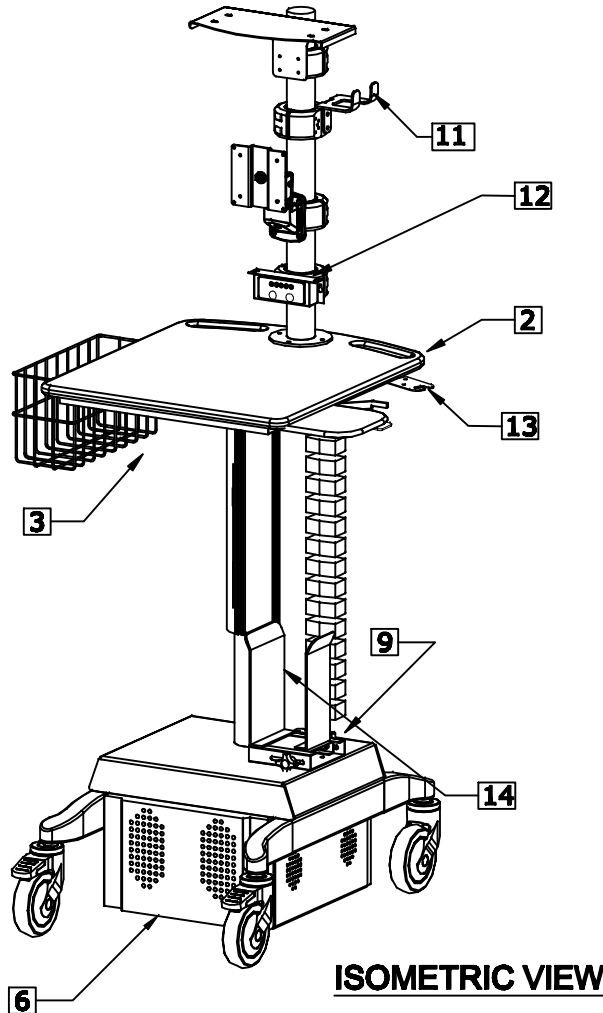

**DESCRIPTION POINT OF CARE CART 'PC910'**

1. AFCZ600 w/VESA 100x100 Complaint Monitor Holder on 24" High Ø2" Pole Clamp Mount w/Camera bracket on top.
2. Worksurface with Handle 24"W x 24"D
3. Wir Basket
4. Lever for height adjustment
6. Removable front and rear access panels
7. (4) Ø5"Casters, (2) Front Locking
8. Holes for ventilation
9. PSTL-54 Battery
10. Wire manager WMF100
11. Scanner Holder
12. LED Battery Status Display
13. Hook for Power Cord
14. CPU99



**ISOMETRIC VIEW**

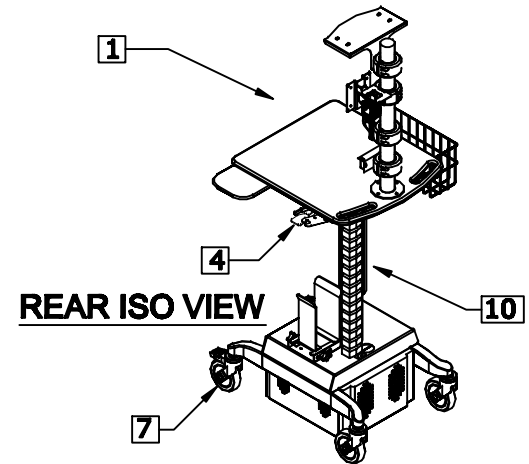

**REAR ISO VIEW**

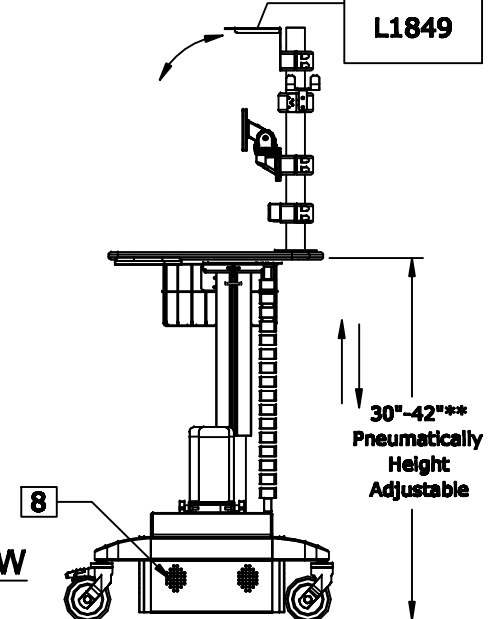

**SIDE VIEW**

NOTES :  
\*\* ± 2"

MATERIAL :

TOLERANCES UNLESS OTHERWISE SPECIFIED  
 FRACTIONAL ± 1/64  
 2 PLC. DEC. ± .01  
 3 PLC. DEC. ± .001  
 ANGULAR ± .5°  
 FINISH √

DRAWN BY : GM/YN

DATE: 09-16-20

DESCRIPTION :

**POINT OF CARE CART**

A P P R O V E D

ENG :

MFG :

QA :

SCALE : N.T.S.

SHEET : 1 OF 2

USED ON :

PATH :

PDF:

**PC910-28\_24x24\_CAM\_1FZ\_1C\_01**