

Celebrating



Information
Technology

CATALOG » Issue 25, Vol. 5

FURNITURE



www.afcindustries.com

afc INDUSTRIES, INC.
Solution creators for working environments™

Contents



MOBILE DATA ACCESS..... 4



MOUNTING SOLUTIONS.....20



RACKING SYSTEMS.....32



INTERACTIVE WORKSTATIONS. .34



ACCESSORIES.....38



STANDARD COLORS.....43

Customer SPOTLIGHT



Information Services
The New York Presbyterian Hospital

“*The Height Adjustable AFC “Red Laptop Carts” that we have deployed at the New York Presbyterian Hospital have been very well received in all areas. Over time we anticipate replacing all of the older battery powered carts with this model. From the ED to the OR’s, the staff like the smaller footprint, ease of movement, height adjustability and ergonomic design. From a cost perspective this less expensive option has helped considerably from a budget perspective.*

Thanks again for all your assistance with our deployment here at the New York Presbyterian Hospital; you have made a difference.”



Phillips66 Lake Charles Refinery
Westlake, LA 70669

“*I just got finished using it in our training room... We mounted it in a central location and because the room is rather small, we can move it to all of our equipment stations perfectly and the quality of the monitor arm is excellent.”*



Massachusetts General Hospital
Harvard Medical School

“*I was out at the assembly site to see the assembled version of the desk we put together.*

It looks pretty terrific: the wiring is elegantly managed, everything moves smoothly and easily, and the little touches (power outlets on the post, USB hubs, under- and over-desk lights, CPU mounts) are all spot-on. I’m assured that assembling the desk in a mirror-image configuration will work very smoothly where needed.

I’m very pleased with the design we’ve come up with, and I again offer my special compliments to the engineer who conceived of the horizontal back-shelf idea for the monitors.”

MOBILE DATA ACCESS



Providing data where and whenever it's needed

Mobile carts bring critical information to Point-of-Care locations throughout Healthcare facilities. Whether it involves admissions, pharmaceutical, radiological or telehealth video conferencing, daily patient care decisions must be accurately made and supported by the most current data available. AFC's array of durable mobile carts is designed to meet this growing need, while incorporating important ergonomic features that make them adaptable to any user.

Our height adjustable units are available with small footprints for easy maneuvering in tight places. Security features protect both sensitive patient information and computer equipment and our carts are built from materials for thorough disinfection. Long-lasting batteries (Hot Swappable/LiFe/SLA Power Supply) can be loaded so that carts can move from area to area, without being connected to electrical outlets, providing uninterrupted power to your workstation wherever, and whenever you need it.

Whatever your need is, AFC can build a mobile cart solution for you.

Where "Camera Caregiving" has come of age!

In today's high tech world, the concept of receiving quality health care from an experienced, licensed physician without leaving home is not such a difficult one to conceive. In fact, an increasing number of physicians are opening up the paths of communication with their patients in a whole new way — providing consultations, drug prescriptions, and other health services via the Telemedicine pathways of the telephone, e-mail, texting and video conferencing.

The advances made in high definition video conferencing and fast network connections have played a major role in the expansion of Telemedicine services on both the clinical and non-clinical levels. Clinicians are able to care for larger patient populations, share information and research, educate their patients and even provide remote monitoring to reduce the costs of chronic care. Patients, on the other hand, have access to more information and data, reduced travel time and anxiety, minimized time off from work and access to specialists as they are required.

AFC Industries has created highly mobile and ergonomic solutions especially for this growing discipline. From something as simple as discussing a case over the telephone, or as complex as using satellite technology and video conferencing equipment to conduct a real-time consultation between medical specialists in two different countries, our Telemedicine carts can fit all situations. Available in a variety of sizes and shapes and equipped with camera holders, these units have become a mainstay in Healthcare IT departments.



Telemedicine Video Cart PC910-303

Our newest **electronically height adjustable** telemedicine cart PC910-303 provides a fully integrated, mobile computing workstation designed for enhanced efficiency when health services through advanced applications are necessary.

Medical and non-medical devices can be easily connected to the carts systems' enabling high definition, real-time images to be shared providing the best diagnosis and care regardless of geographical or physical constraints. The combination of a compact design with a strong ergonomic focus makes this cart ideal for point-of-care applications.

Removable and lockable work surface

A HDPE¹ work surface now available with antimicrobial protection.

Easy Grip

Front and back handles facilitate grip and access from any user position.

Retractable Keyboard Tray

The retractable keyboard tray with a sliding mouse tray for both left and right-handed users.

Mobility

Four 5-inch casters with round tread wheels for ease of movement (the front two are locking).



Monitor Mounts

VESA 75/100 compliant monitor bracket with horizontal and vertical tilt.

Lockable Enclosure

The enclosure provides ample room for router, STI module and video module.

Electronic Height

Electronic height adjustment at the touch of the button to be comfortable for the end user.

Cable Management

Multi-channel wire manager keeps wires neat and unobtrusive.



Telemedicine Cart TMC300

The telemedicine cart TMC300 is a **pneumatically height adjustable** unit with an optional battery power source for true mobility. It is available with standard VESA-compliant mounting brackets (75/100), a locking drawer, camera mount and room for an all-in-one or a thin client computer. Sleek, efficient and easy to move with the integrated handles and four 5-inch casters.



Telemedicine Cart XPC1926

The XPC1926 cart comes with two **pneumatically height adjustable** surfaces. Fully articulating VESA-compliant monitor arms, a spacious 15"W x 11"D x 4"H locking drawer, retractable keyboard tray, enclosure for CPU and the battery power source, and camera mount makes this cart an ideal unit for video conferencing.



Plasma Cart™ XLCD300-01

The Plasma Cart™ is ideal for meetings, presentations, seminars, conferences and signage. Accommodating up to a 55" flat screen, this stable unit is a perfect solution for data and video access as you bring your large flat screen and necessary electronic equipment to where it is needed. All the components of the Plasma Cart are **height adjustable**. Internal wire management is built in behind easy-to-remove access panels.



Pole Cart™ MPC200

A truly customized item. The Pole Cart™ begins as a blank canvas with a wheeled base and main pole assembly. Everything you select to include becomes **height adjustable** and **can rotate 360° around the pole**. Monitors, CPU holders, keyboard trays, camera mounts, additional shelves, scanner and speaker holders and more. Built-in wire management keeps everything neat and tidy. A product that will meet your needs because you "design it".

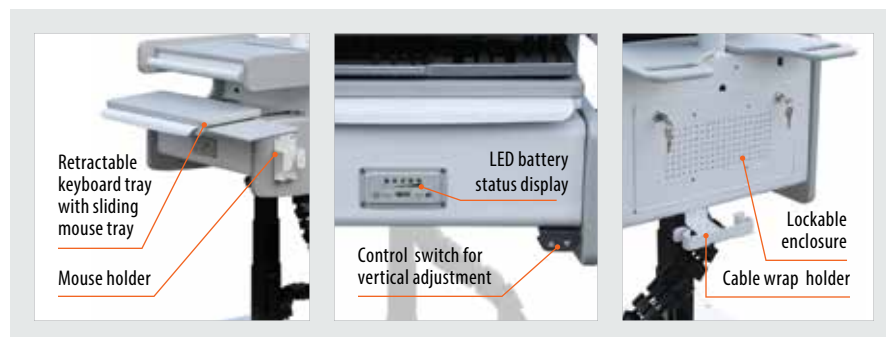

Standard Colors



Gray Putty Black

HDPE Colors

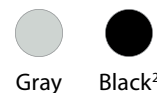

Gray Black²

Specifications

Sizes	Width	Depth
Work surface	17.75"	20.75"
Footprint	20.66"	25"
Keyboard tray	18"	8"

Height of work surface from the floor: ~37" to 49"

¹ High-density polyethylene (see page 42 for more information)

² Available with antimicrobial finish

PC Cart™

Our PC (Point-of-Care) Carts™ are designed for maximum flexibility and streamlined movement. They enable physicians to bring advanced computer technology to the bedside, operating room and any other location where patients will benefit from today's medical computer applications.

The PC Carts™ feature a low profile, small footprint, **pneumatic** (optional electronic) **height adjustment**, and support all-in-one computers as well as separate thin client and monitor. For maximum portability, the carts can accommodate a battery power source (go to www.afcindustries.com/Batteries for power supply options).

Features and Benefits

Pneumatic height adjustment

Thorough disinfection for "clean room" use

Supports all-in-one computer as well as separate thin client and monitor

Mounting for all-in-one computer or standard monitor VESA (75/100)

Phenolic, HDPE¹, or laminate work surface

Seamless integration of handles into the work surface on all four corners for easy grip from any user position



Optional

Electronic height adjustment

Keyless electronic lock for utility drawer and divider to facilitate administration of care in two-patient rooms

HDPE retractable keyboard tray with ergonomic negative and positive tilt and swivel

Power supply, wire manager, mouse holder, wire basket, scanner holder, and additional accessories available

Antimicrobial finish (see page 42 for more information)



PC Cart™ 910

The PC Cart™ 910 combines a streamlined look and enhanced functionality with the hallmark durability and ergonomic design of AFC's mobile workstations.

With an all-in-one computer, the height-adjustable PC 910 offers a battery that can run for up to 25 hours before recharging (depend on power draw of connected components). UL 60601-1 compliant, it is safe to use throughout facilities. Fleet management software allows for IT monitoring, management, and programming of carts for location, battery status, and scheduling of computer shutdown, recharging and maintenance.

Monitor Mounts

Supports all-in-one computer as well as separate thin client and standard monitor VESA (75/100).

Easy Grip

Cutout handles on all corners facilitate grip and access from any user position.

Cable Management

Multi-channel wire manager keeps wires neat and unobtrusive.

Mobility

Four 5-inch casters with round tread wheels for ease of movement.

Pneumatic Height Adjustment

Side lever easily adjusts the height of the work surface to be comfortable for the end user.

Antimicrobial Finish

A HDPE work surface now available with antimicrobial protection.

Electronic Lock

Utility drawer with a keyless electronic lock and divider to protect documents and medications.

Adjustable Keyboard Tray

The retractable phenolic keyboard tray features tilt, swivel, and a sliding mouse tray for both left and right-handed users.

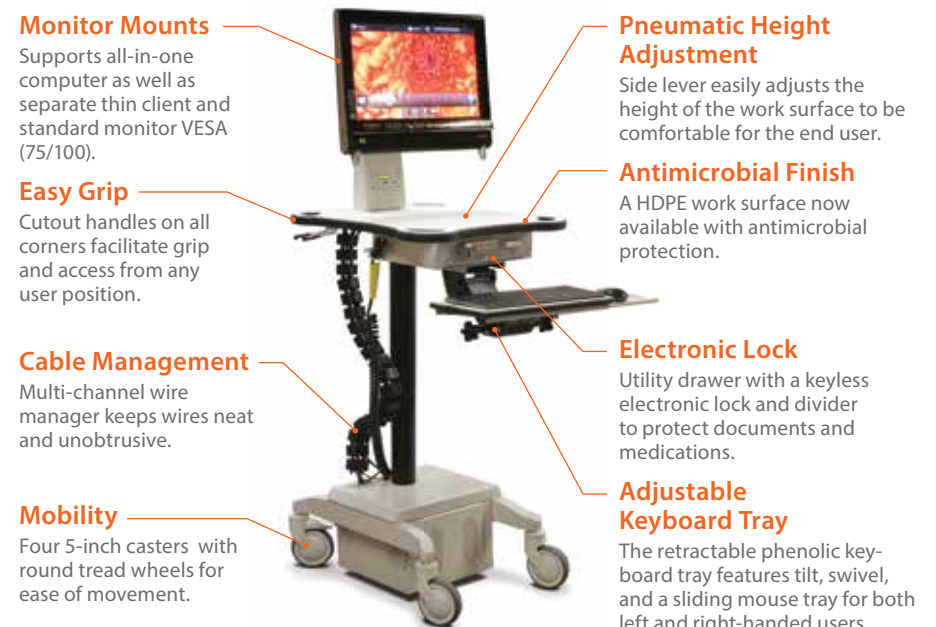

Standard Colors



HDPE Colors

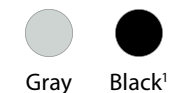

Specifications

Sizes	Width	Depth
Work surface	24"	24"
Footprint	20"	24"
Keyboard tray	19"	8"

Height of work surface from the floor: ~30" to 42"

¹ High-density polyethylene (see page 42 for more information)

¹ Available with antimicrobial finish

PC Cart™ 900

For high traffic areas where the base width and height are crucial, AFC offers the carts with a small footprint and an overall height of less than 6 inches from the floor. It has the same **pneumatic height adjustment** features and ease of mobility as larger models. The PC Cart™ 900 easily adapts to the end users ergonomically and its locale environmentally.

Available with an optional scanner holder and additional accessories (see page 40), the PC Cart™ 900 can easily adapt to all work situations.

Sample Configurations

A. PC Cart™ 900

- Pneumatic height adjustment of work surface
- Rounded phenolic work surface with four built-in handles
- VESA (75/100) monitor arm
- Retractable keyboard tray with sliding mouse tray
- Mouse holder # M001
- Base-mount CPU holder # CPU-101
- 4" dual casters (the front two are locking)



B. PC Cart™ 900

- Pneumatic height adjustment of work surface
- Rounded HDPE work surface with four built-in handles
- VESA (75/100) monitor arm
- Thin client
- Utility drawer with electronic lock
- Retractable keyboard tray with sliding mouse tray
- Mouse holder # M001
- Scanner holder # S01
- 4" dual casters (the front two are locking)



Standard Colors



Gray Putty Black

HDPE Colors

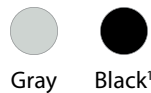

Gray Black¹

Specifications

Sizes	Width	Depth
Work surface	24"	24"
Footprint	18"	18"
Keyboard tray	19"	8"

Height of work surface from the floor: ~30" to 42"

¹ Available with antimicrobial finish

PC Cart™ 800

This multi-purpose and functional cart is ideal for all healthcare business and service sectors. The PC Cart™ 800 has a rectangular base for stability.

Completely modular. Select from our full range of monitor arms, CPU holders, keyboard trays and other accessories to complete your configuration. Available in several colors to match most color schemes or to stand out for easy identification.

Monitor Mounts

Clamp-mount Z-series arm with its 20-inch extension allow you to position your monitors at any viewing level, angle and depth from the viewer.

Choice of Work Surface

Choose from a laminate, phenolic or HPDE work surface.

Pneumatic Height Adjustment

Side lever easily adjusts the height of the work surface to be comfortable for the end user.

Rear Handle

Rear mounted handle provides control and ease of maneuverability.

Mobility

Four-inch dual casters. The front two are locking for rigid stability when you need it.



Laminate Colors



HDPE Colors

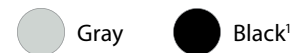

¹ Available with antimicrobial finish

Specifications

Sizes	Width	Depth
Work surface	22 1/2"	20"
Footprint	19"	20"
Keyboard tray	18"	8"

Height of work surface from the floor: ~30" to 42"

Alternate Configuration



A. PC Cart™ 800:

- Pneumatic height adjustment of work surface
- HDPE work surface with two built-in handles
- Grommet-mount monitor arm # AFCPOLE2MH-1
- Retractable keyboard tray # KB03
- Base-mount CPU holder # CPU-99

PC Cart™ 500

This cart has an all-metal body for easy cleaning and disinfecting. The PC Cart™ 500 is available with **pneumatic** or **electronic height adjustment** and with or without a battery power source (go to www.afcindustries.com/Batteries for power supply options).

Monitor Mounts

Supports all-in-one computer as well as separate thin client and standard monitor VESA (75/100).

Retractable Keyboard Tray

Retractable tray attaches under the work surface and easily slides the keyboard out of the way when not in use.

Cable Management

Multi-channel wire manager keeps wires neat and unobtrusive



Easy cleaning

All-metal body enables disinfection and "clean room" use.

Pneumatic Height Adjustment

Side lever easily adjusts the height of the work surface to be comfortable for the end user.

Maximum Portability

Power supply unit includes long-lasting battery so the cart can move from area to area without being connected to electrical outlets.

Sample Configurations

A. PC Cart™ 500

- Pneumatic height adjustment
- Twin monitor arm # 2MH
- Retractable keyboard tray with sliding mouse tray
- Rear handle
- Lockable CPU holder with meshed side and openings for wires and air circulation
- Mouse holder # M001
- Wire basket # WB-100
- Cup holder # MCH-100
- Multi-channel wire manager # WMF200
- Power supply shelf



Twin monitor arm



Lever for pneumatic height adjustment

B. Dual PC Cart™ 500

- Pneumatic height adjustment of work surface
- Locking laptop platform with 12" pneumatic height adjustment
- Utility drawer with electronic lock
- Rear handle
- Wire basket # WB-100
- Multi-channel wire manager # WMF100
- Power supply shelf



Laptop platform with pneumatic height adjustment



Lever for pneumatic height adjustment

C. Deluxe PC Cart™ 500

- Electronic height adjustment
- VESA (75/100) monitor arm
- LED battery status display
- Rear handle
- Lockable CPU holder with meshed side and openings for wires and air circulation
- Wire basket # WB-100
- Multi-channel wire manager # WMF200
- Power supply unit (battery included)



Control switch for vertical adjustment

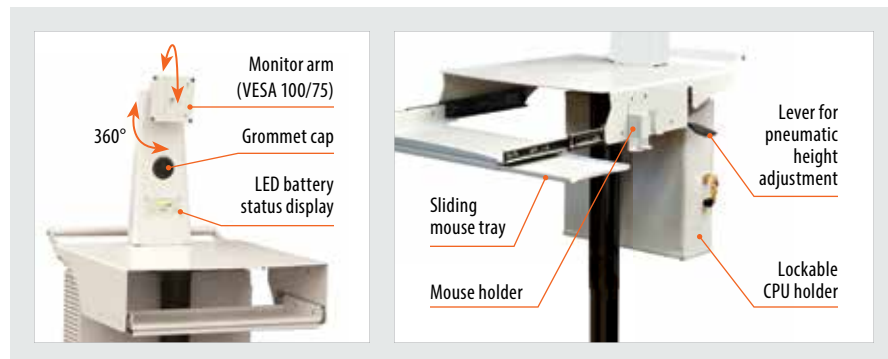

Standard Colors



Gray Putty Black White

Specifications

Sizes	Width	Depth
Work surface	20"	20"
Keyboard tray	19"	8 1/2"
Rectangular base	20 1/2"	24"

Height of work surface from the floor: ~30" to 42"

Some PC Carts™ Accessories



Antiseptic wipe holder



Biohazard waste holder



Wire basket



Scanner holder

Laptop Carts

Our highly adaptable LPC750 is designed to hold a laptop. This cart features **pneumatic height adjustment** and offers a compact look. Our smallest footprint and a base height of less than 6 inches makes it suitable for small work areas. It's specially designed star-shaped base with 3-inch wheels delivers smooth and fluid mobility while maintaining its overall stability.

Secure Laptop Cover

Half-inch thick laptop cover using tamper proof screws.

Front & Back Handles

Integrated handles in the front and back for ease of maneuverability.

Retractable Keyboard Tray

The retractable metal keyboard tray and a sliding HDPE mouse tray with friction lock when pulled out or in.

Accessories

Height adjustable brick holder with cutout at the ends, metal storage bin, and wire basket.

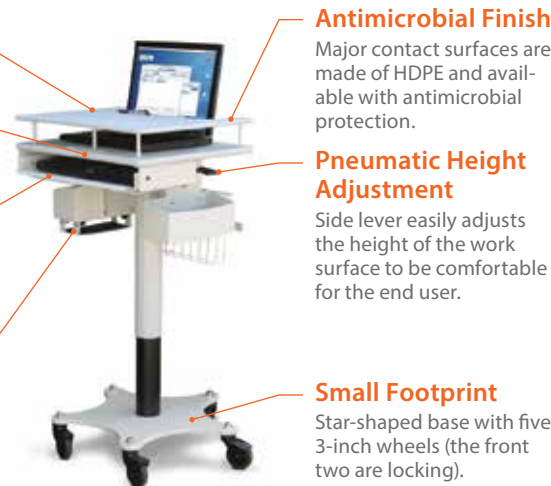

Antimicrobial Finish

Major contact surfaces are made of HDPE and available with antimicrobial protection.

Pneumatic Height Adjustment

Side lever easily adjusts the height of the work surface to be comfortable for the end user.

Small Footprint

Star-shaped base with five 3-inch wheels (the front two are locking).

The LPC200 has a 24-inch diameter five-prong base footprint and an additional base weight for increased stability. Optional Hot Swappable Power Supply provides uninterrupted power to your workstation wherever and whenever you need it. Simply swap out the drained battery from the cart for a fully recharged battery from the recharging station for continuous workflow.

For this cart we offer multiple color combinations for easy identification and to match the surrounding decor.

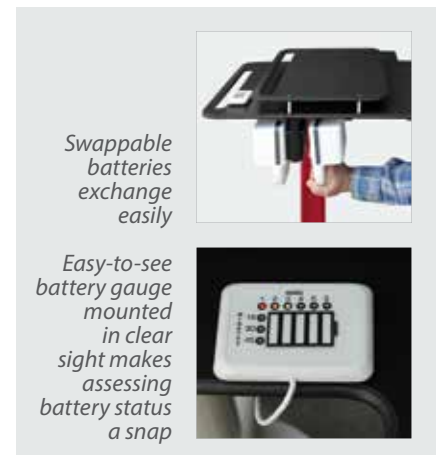

Features and Benefits

Pneumatic height adjustment

Thorough disinfection for "clean room" use

Built from cold-rolled steel with epoxy-powder-coated finish

Retractable metal keyboard tray with sliding mouse tray

Optional

Lockable laptop cover

Retractable power cord

Hook for cable

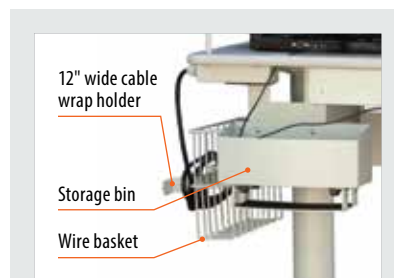

Laminate Colors



HDPE Colors

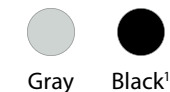

¹ Available with antimicrobial finish

Specifications

Sizes	Width	Depth
Work surface	18"	25"
Footprint	24" diameter	
Keyboard tray	18"	8"

Height of work surface from the floor: ~31" to 47"

HDPE Colors

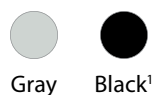

¹ Available with antimicrobial finish

Specifications

Sizes	Width	Depth
Work surface	21"	12"
Footprint	22" diameter	
Keyboard tray	18"	8 1/2"

Height of work surface from the floor: ~28" to 44"

More Configurations



A. Laptop Cart # PCLS with the antimicrobial HDPE top



B. Laptop Cart # LPC100 with laminated top



C. Laptop Cart # LPC03 with a fixed height and phenolic top

Tablet Carts

At AFC Industries we are committed to creating end-user solutions driven by new technologies. The latest advancements in data access mobility point to the handheld tablet as an increasing popular device. Far more flexible and friendly than even small laptops, these handheld devices combine the features of a smart phone, a laptop, an iPad and a gaming console.



A. Tablet Cart TBC150-201

Our new tablet carts have a 24-inch diameter five-prong base footprint for increased stability. The TBC360-101 features a Z-series holder, and the TBC360-GN-201, a gooseneck tablet holder. This allows you to set the viewing angle at a comfortable setting for viewing podcasts, webcasts, reading journals and periodicals.

NEW



B. Tablet Cart TBC360-101

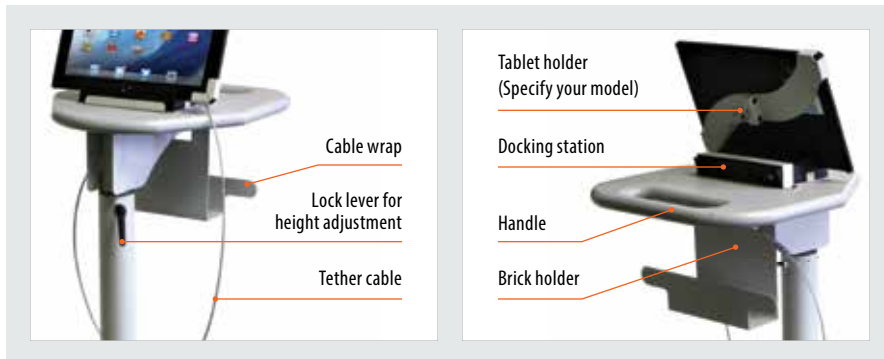

C. Tablet Cart TBC360-GN-201

HDPE Colors



¹ Available with antimicrobial finish

Specifications

Sizes	Width	Depth
Work surface	12 1/2"	13 1/2"
Footprint	19"	19"

Height of work surface from the floor: ~33.5" to 44.5"

Tablet Mounting Option



VESA 75/100 compliant mount, can be used with a tablet holder

Standard Colors¹



¹ Custom colors available

Telescopic Cart™

The Telescopic Cart™ is designed to accommodate tight spaces. The work surface is **electronically height-adjustable** to enhance comfort and ease of use, whether the operator is seated or standing. Available in different width and depth combinations, the cart can accommodate up to two flat panel monitors.

All sizes are customizable with grommet-mount or clamp-style monitor arms, multiple laminate finishes and colors (see page 43), keyboard arms and trays, and larger casters for two additional inches of height.

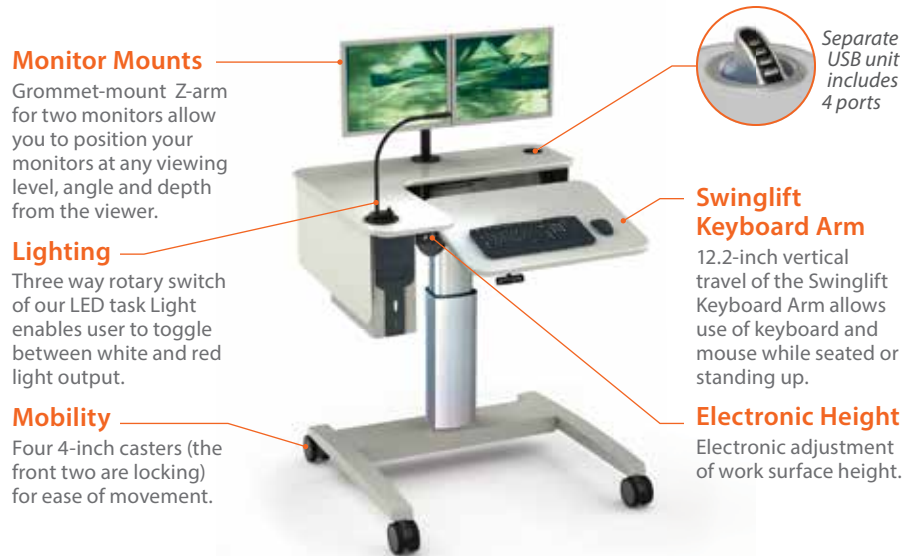

Features & Benefits

Electronic height adjustment of work surface

Particle-board-core top with your choice of high-pressure laminate finish (for standard colors, see page 43)

Cold-rolled 11-gauge steel frame with epoxy-powder-coated finish for durability

Optional

Electronic tilt of work surface

Chemical-resistant phenolic top and bottom surfaces

USB hub embedded in the work surface and other accessories (see page 38)

Work Surface Shapes

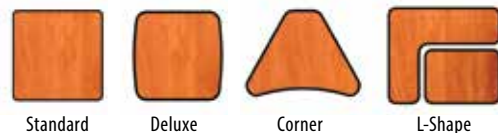

Specifications

Work Surface Shapes	Width	Depth
Standard	24", 30", 36"	24", 30", 36"
Deluxe	24", 30", 36"	24", 30", 36"
Corner	24", 30", 36"	24", 30", 36"
L-Shape	36", 42"	24", 30", 36"

Height of work surface from the floor: 30" to 46"

Sample Configurations

A. Telescopic Cart™ 36"W x 24"D:

- Electronic height adjustment of work surface
- Deluxe work surface shape
- Two grommet-mount monitor arms # AFC02
- Keyboard arm # KA6000 with keyboard tray # TR2000
- Bottom shelf with cutout



B. Telescopic Cart™ 30"W x 30"D:

- Electronic height adjustment of work surface
- Standard work surface shape
- Chemical-resistant phenolic work surface and bottom shelf
- Grommet-mount twin monitor arm # AFCPOLE2MH-1



C. Telescopic Cart™ 24"W x 24"D:

- Electronic height adjustment of work surface
- Deluxe work surface shape
- Clamp-mount monitor arm # AFCPOLE
- Retractable keyboard tray # KB01
- Adjustable CPU holder
- Wire basket # WB-100
- Wire manager # WMF100
- Base-mount CPU holder # CPU-99



D. Telescopic Cart™ 30"W x 24"D:

- Electronic height adjustment of work surface
- Corner work surface shape
- Keyboard arm # KA6000 and tray # TR2000 with sliding mouse tray



Configure your own Telescopic Cart™ with our INTERACTIVE BUILDER at www.afcindustries.com/telescopiccart

MOUNTING SOLUTIONS



Making the most of limited-space

High traffic areas. Tight places. Operating rooms and emergency rooms. Inside and outside patient rooms. These are just some of the areas that are perfectly suited for AFC's variety of mounting solutions. Height-adjustable versions for seated or standing positions. Adaptable to any user. Making empty wall space productive.

Decentralizing the availability of data for a greater return on investment in plant and human capital.

Combo Arms AFC7808 and AFC7810 Series

Our flexible AFC7808 and AFC7810 series offer **height-adjustable**, low-profile, user-friendly solutions for access to electronic records where space is at a premium. The wall mount accommodates most operators, in sit-to-stand positions. When not in use, it folds up neatly to the wall, tucked away and unobtrusive.

The AFC7810 arm has an additional 10-inch vertical monitor adjustment, as well as, 35° of forward and backward tilt to make sitting or standing viewing more comfortable.

Pneumatic Height Adjustment

The arm is pneumatically height adjustable within a 12-inch range and can be locked in any position you chose.

Flexible

Arm vertically adjusts on wall mounting track and has full range of swivel motion at each joint to accommodate different positions and applications.

Integrated Wire Management

Integrated wire manager for clean, concealed and neat routing of cables.

Monitor Mounts

VESA 75/100 compliant monitor bracket with horizontal and vertical tilt and 3-inch range of height adjustment.

Antimicrobial Finish

Light-weight aluminum construction with anti-microbial coatings for thorough disinfection.

Low Profile

Keyboard tray with handle and sliding mouse tray easily folds up, saving space when not in use.

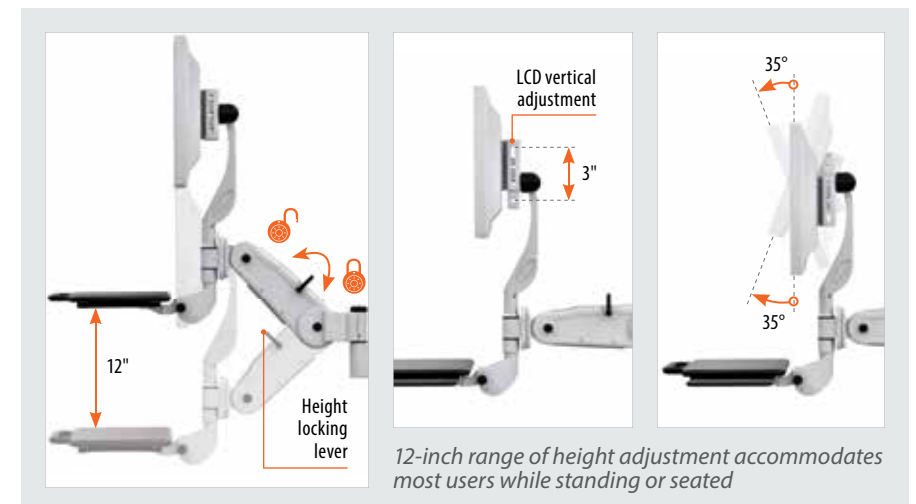
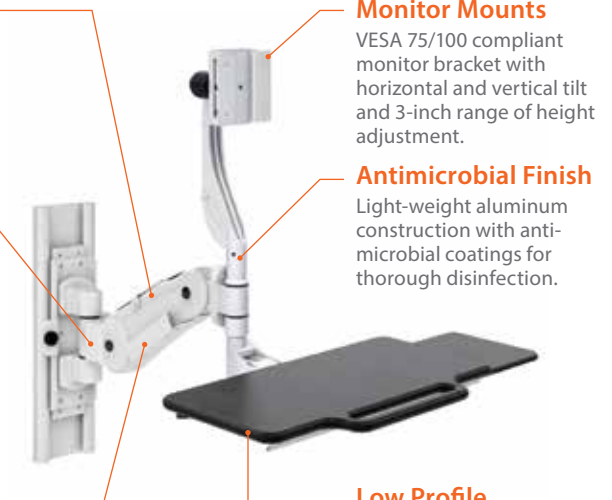

A. Pneumatically height-adjustable arm AFC7808 on 18-inch wall track

Features & Benefits

- Light-weight aluminum construction for easy operation
- Antimicrobial coatings for thorough disinfection and safe use throughout medical facilities
- Sit-to-stand work positions
- Height locking mechanism at any position for safety, stability, and varying loads
- Full range of swivel motion at each joint
- Keyboard folds for low profile and has a safety lock
- 12-inch range of height adjustment accommodates most users
- 34" when fully extended from the wall
- 8.5" when retracted and folded to the wall
- VESA 75/100 compliant monitor bracket with horizontal and vertical tilt and 3-inch range of height adjustment
- Integrated wire management

Optional

- Can be mounted directly on a wall or desk
- Supplemental 12" or 20" extension arm
- Wall mounted track with safety stoppers on both ends (from 18" up to 84" long with one-inch increment)

Color

- Standard color: Gray (call for custom colors)



B. Combo arm AFC7808 with 12-inch extension on 18-inch wall track

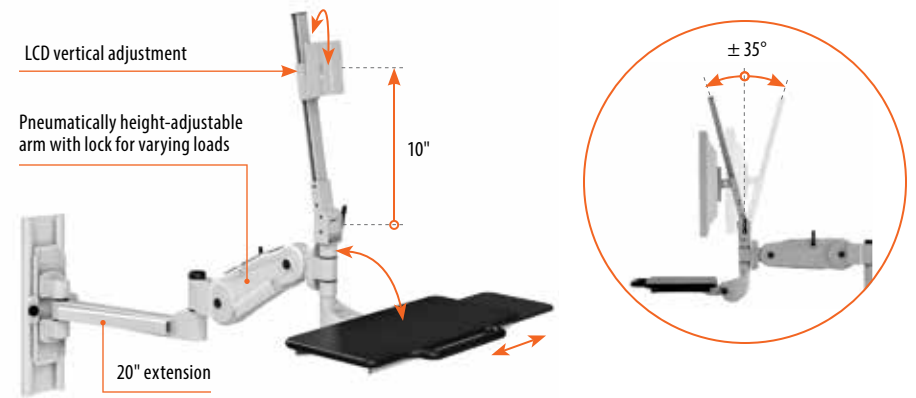

C. Combo arm AFC7810 with 20-inch extension on 18-inch wall track

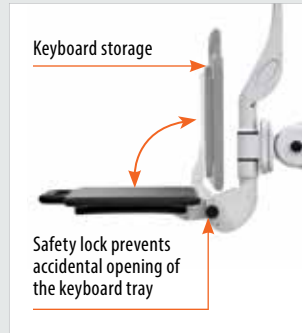

Keyboard tray with integrated handle easily folds up, saving space when not in use



Mouse tray slides to accommodate left and right-handed users



With the keyboard folded up, total system depth is as little as 8.5 inches



Clean, concealed and neat routing of cables through the cable management system



Mounting Options



Vertical mounting



Horizontal mounting



Desktop mounting

More Mounting Solutions with AFC7808 Series



Monitor arm



Keyboard arm



Laptop arm



Wall Mounts

AFC Wall Mounts are the perfect space-saving solution for areas that require data access in place of a bulky computer desk or traditional workstation. By mounting the workstations to the wall, you are able to free up and provide uncluttered floor space in exam rooms, hallways, public spaces and other high traffic areas where computer access for multiple users is necessary. Mounted directly to a wall for a fixed height, or height adjustable when used with our wall mount track, our solutions provide you with the options you need to ergonomically get the job done and protect your workforce.

Features and Benefits

Wall track with safety stoppers on both ends (from 18" up to 84" long with one-inch increment)

All components are individually and easily adjustable in increments of 2 inches

VESA-compliant monitor holder that can be adjusted from portrait to landscape view and tilted to avoid glare

Foldable and retractable keyboard arm with sliding mouse tray

Adjustable CPU holder

Optional

Horizontal or vertical positioning

Double monitor holder on single track

Horizontal track for multiple monitors

Shelves, UPS holder, mouse holder, and other accessories (see page 40)

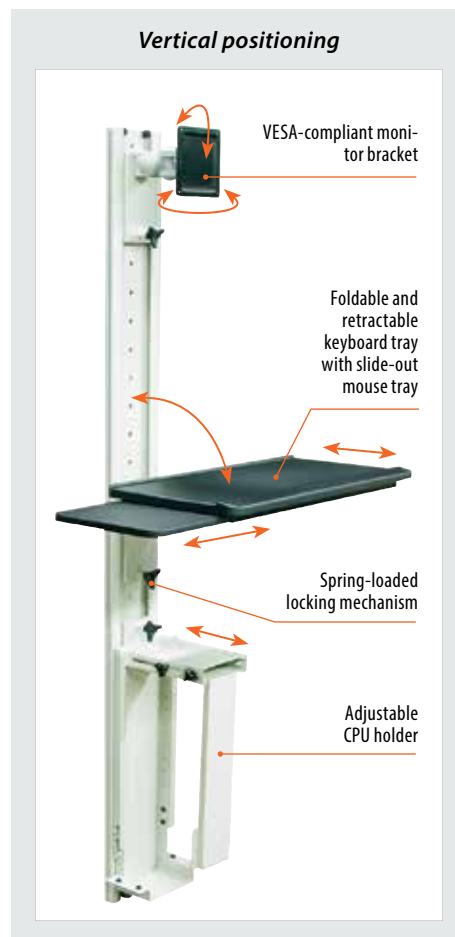

Optional Monitor Arms for Wall Mounts

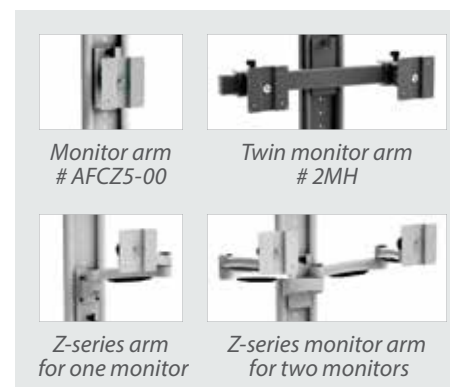

Configure your own Wall Mount with our INTERACTIVE BUILDER at www.afcindustries.com/wallmount

Sample Configurations

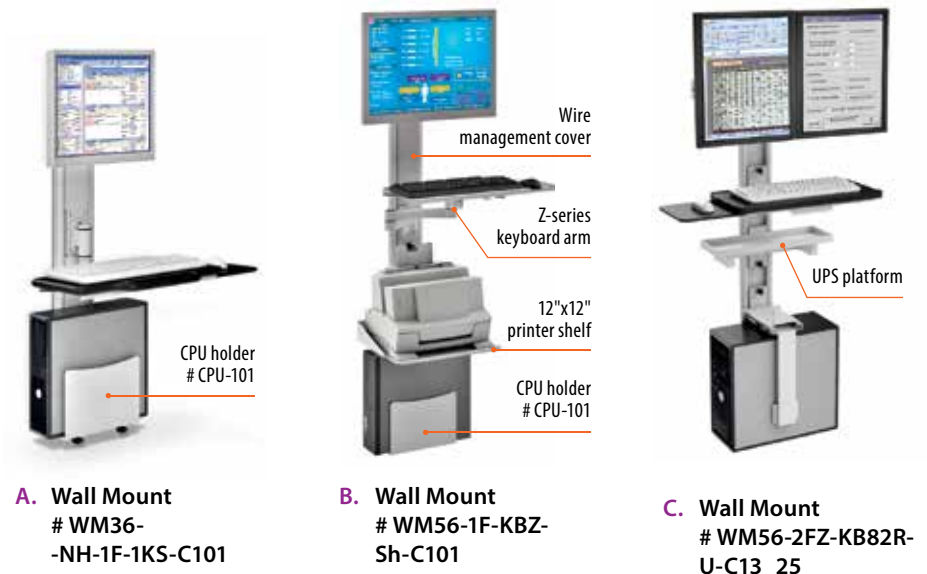



i-Center™

The space-saving i-Center™ is an attractive wall-mounted workstation that enables computer access wherever needed, without utilizing floor space.

The i-Center™ includes a fold-down keyboard tray with a damper for smooth operation and a VESA-compliant monitor holder. It accommodates any standard computer and turns empty wall space into a handy work area. The i-Center™ features all metal or laminated front and side walls that can be specified to match room décor, and mounts easily with grommet holes to allow cabling.

Features and Benefits

Removable front panel with optional security screws and lock for keyboard shelf to prevent theft

Fold-down keyboard tray with damper for smooth operation

VESA-compliant monitor holder

Grommet holes for cabling

All metal or laminated front and side walls can coordinate with room décor

Multiple colors available (for standard colors, see page 43)

Custom sizes available

Specifications

Width: 21 1/8"– 40"

Height: 19 1/2"– 50"

Depth: 3"– 9"



Optional

Self-closing keyboard tray

Electronic lock

Optional accessories include: CPU enclosure, mouse holder, scanner holder, cable management, power strips, and fan

Sample Configurations

A. i-Center™ # IR900-101 (25"W x 5"D x 43"H) with electronic height adjustment and self-closing keyboard tray

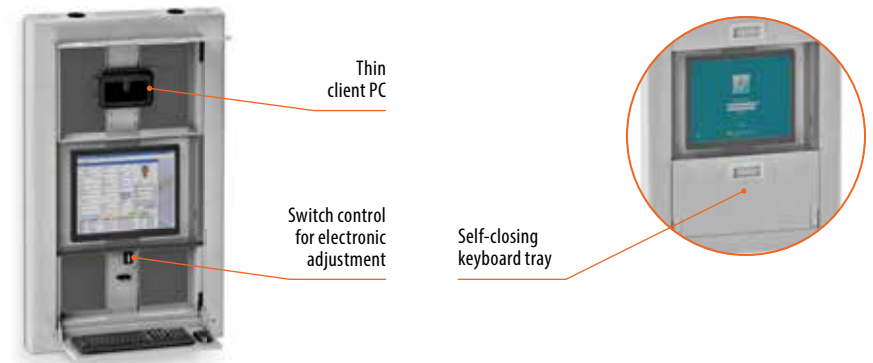

B. i-Center™ # IR200-007 (36"W x 6"D x 29 1/2"H) with self-closing keyboard tray, compartment for CPU and storage

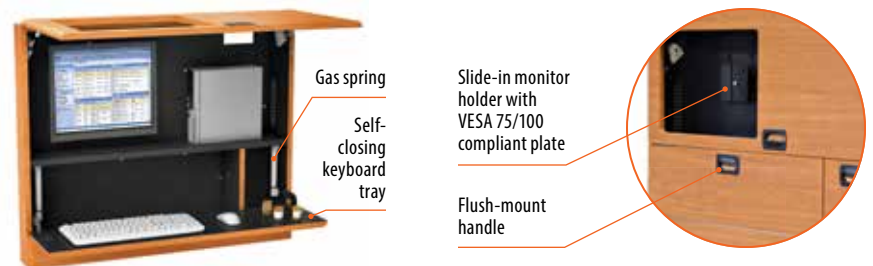

C. i-Center™ # IR600 (25"W x 4"D x 19 1/2"H) for laptop with keyless lock

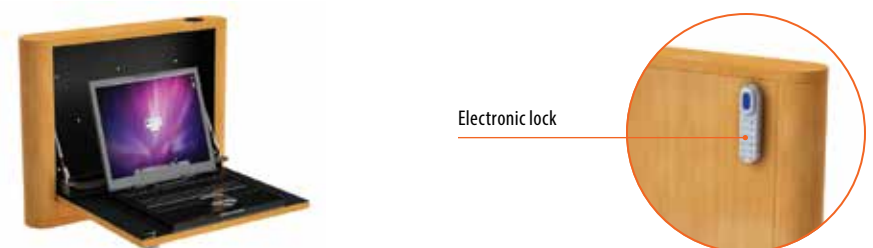

D. Metallic i-Center™ # IR850-002 (26"W x 4"D x 26"H)

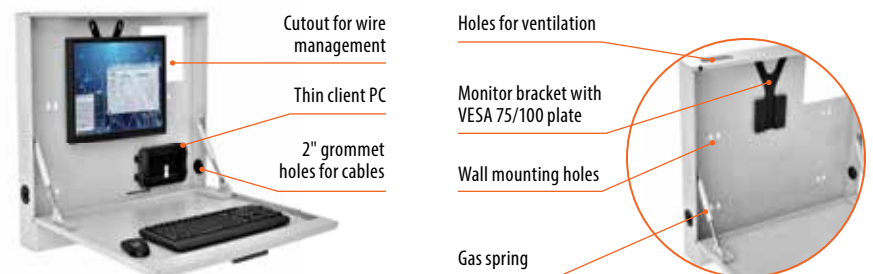



Three-row Video Wall for 12 monitors

Video Wall

The Video Wall consists of one or more tracks for sliding the monitor arms from left to right, where every single arm allows tilting up-down and left-right, as well as micro-adjustment to eliminate gaps between monitors. Z-arms give each monitor an ample range of motion, allowing you to position them in several different viewing arrangements.

Features and Benefits

Aluminum track with mounting holes and safety stopper at both ends allows monitor holders to slide

Horizontal or vertical mounting of tracks

Z-arm monitor holders with extension, tilt, and pan motion; arms have varying length to provide parabolic shape for optimum viewing

VESA-compliant monitor holder that can be adjusted from portrait to landscape views and tilted to avoid glare

Combination setup allows horizontal and vertical adjustment of the monitors

Monitor extends from 4" to 20" from the wall

Non VESA-compliant monitor holders available for larger flat screens

Optional Monitor Holders¹



¹ Tilt and pan only



The outer monitor arms are longer than at the center, which lets you create a comfortable viewing arc. When laid out straight, the monitors can get as close as 4" to the wall.



The Video Wall's freedom of motion allows you to combine monitors of different shapes and sizes, in any arrangement, without gaps.

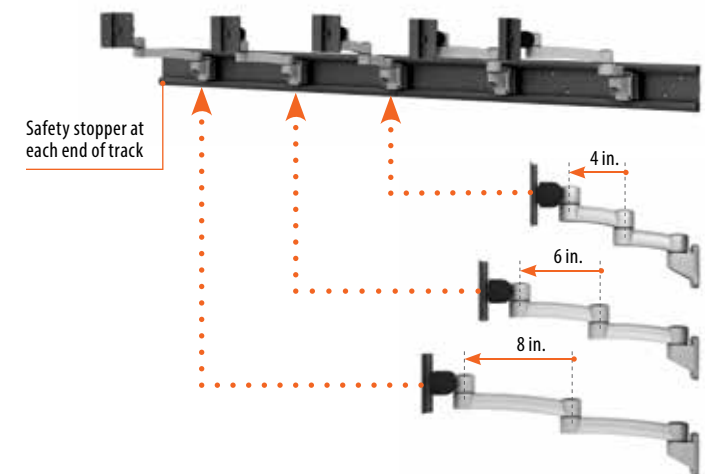



Floor Post™

The Floor Post Series™ creates a more effective, comfortable, and productive work environment. Based on your specifications, you can have unlimited configurations for any task. Its space saving design also allows multi-side (front/back/side) user capability.

The Floor Post Series™ can be mounted to various floor surfaces. Monitor, keyboard arms, CPU holders, shelves and other accessories can be made height adjustable on a secure track making this unit suitable for multi-users.

Features and Benefits

All components are individually adjustable

Spring-loaded locking mechanism for simple and easy height adjustment (depending on item)

Built-in wire management

Monitor holders of your choice: AFC10E/F/G, AFCZ5-00, AFC7808M_01 (see page 38)

CPU holders of your choice: CPU-101, CPU13-25, CPU-09, CPU-919, or CPU-CS909 (see page 40)

Specifications

Base footprint: 16"W x 16"D

Overall height from the floor can be customized to meet your specifications

Optional

Double-monitor holder

Foldable and retractable keyboard arm with sliding mouse tray

Additional shelves and other accessories

Camera holder

Available Colors



Gray Putty Black White



Floor Post #FP04

Sample Configurations

A. Floor Post™

- 60"H track
- Height-adjustable camera holder
- Monitor arms # AFCZ5-00
- 24"W x 16"D work surface
- 18"W x 10"D retractable keyboard tray
- CPU holder # CPU-101
- Wire basket # WB-100
- Floor-mount base



B. Floor Post™

- Two 50"H tracks
- Pneumatically height-adjustable monitor arm # AFC7808M_01
- Monitor arm # AFCZ5-00
- Metal shelf
- CPU holder # CPU-101
- Wire basket # WB-100
- Floor-mount base



C. Floor Post™

- 50"H tracks
- Height-adjustable printer shelf
- Pneumatically height-adjustable combo arm # AFC7810 with 12-inch extension
- CPU holder # CPU-102
- Floor-mount base



NEW

We also offer a Pole Station™ with a round metal base that is fixed to the floor.

D. Pole Station™

- Gray epoxy-powder-coated finish pole with built-in cutout for wire management
- Height of pole from the floor: 64"
- Z-series monitor arm # AFCZ588-01
- Z-series keyboard arm with sliding mouse tray # ZKB-P
- Pole-mount CPU holder # CPU-101
- Floor-mounted 16" diameter metal base (has to be bolted)



RACKING SYSTEMS



Enhancing and organizing your workspace

AFC understands the need to implement ergonomics in all work environments, which is why our racking systems are designed and manufactured to fit the end users. On-staff engineers can customize racking systems to meet your specific requirements.

The SmartRack™ is a modular space-saving solution that accommodates a variety of technical equipment. Highly versatile, it comes in multiple configurations for mounting LCDs, CRTs, CPUs, and all standard 19-inch rack-mount equipment.

Features and Benefits

Cold-rolled 11-gauge steel frame with epoxy-powder-coated finish

Particle-board-core top with your choice of high-pressure laminate finish

Customized work surfaces available edged with T-molding/bumper molding

Work surface and shelves are height-adjustable in one-inch increments

Customized metal or wood shelves, fully adjustable and tiltable

Multiple colors available (for standard colors, see page 43)

Built-in wire-management conduits

Glides and additional accessories available

Specifications

Width of frame: 24", 30", 36"

Depth: 24", 30", 36"

Height of frame: 36", 48", 60", 73", 83"

Two-inch twin casters (the front are locking)



Configure your own SmartRack™ with our INTERACTIVE BUILDER at www.afcindustries.com/smartrack

Sample Configurations

A. SmartRack™ 30"W x 30"D x 86"H:

- 30" wide frame
- Flipper cabinet # FC
- Six plastic bins
- Standard work surface shape



B. SmartRack™ 30"W x 30"D x 86"H:

- 30" wide frame
- Flipper cabinet # FC
- Metal shelf
- Standard work surface shape
- Z-series arm for two LCD monitors # AFCZ588-02
- Keyboard arm # KA6000
- Keyboard tray # TR2000 with sliding mouse tray
- Adjustable CPU holder # CPU 13-25



C. SmartRack™ 60"W x 30"D x 76"H:

- Two 30" wide frames
- Two metal top shelves
- Metal tilt shelf
- Rack-mount brackets 7"H x 4"D
- Adjustable phone arm # TA001
- Standard work surface shape
- Z-series monitor arms # AFCZ588-01 and # AFCZ588-02
- Two keyboard arms # KA6000
- Two keyboard trays # TR2000 with sliding mouse trays
- Two rolling shelves



INTERACTIVE WORKSTATIONS



Making work comfortable and productive

At AFC Industries, we take the science of work place ergonomics very seriously. We understand that different users have different needs. AFC workstations are electronically height-adjustable at the touch of a button. Independent adjustment of monitor height and focal length for optimal viewing. Digital readouts to preserve and easily return to your ideal settings for surface and monitor placement. Available with surface tilt and a host of valuable features.

Our flexible workstations come in a wide variety of sizes, shapes, multi-tiered designs, and color options that accommodate virtually any location and workplace need. Truly flexible, adjustable and they adapt to you!

Features & Benefits

Electronic height adjustment of work surface

Monitor arms with horizontal, vertical, and tilt adjustment

Cold-rolled 11-gauge steel frame with epoxy-powder-coated finish

Pressurized and scratch-resistant long-lasting laminates in a variety of colors (for standard colors, see page 43)

Complete wall-to-wall installation services

Optional

Electronic adjustment of monitor height and focal length

Advanced warm/cool air environmental control system regulated at the workstation

Pop-up data ports and a built-in USB hub embedded in the work surface

Light and sound barrier partitions

Partitions with removable lower metal panel for back CPU access and continuous cable management

The Whitestone™

The Whitestone™ reading workstation features complete electronic adjustment capabilities — for surface height in sit or stand positions, surface tilt, and both vertical and horizontal adjustment of monitors.

The monitor brackets support large monitors weighing up to 100 lbs, responding to a growing interest in larger images. We have added acoustical properties to our wraparound privacy partition to reduce extraneous sounds and create a quieter environment for concentration. Multi-channel cable management keeps wires neat and unobtrusive.

Electronic Monitor Mounts

LCD monitor arms on telescopic drives with electronic adjustment of monitors' height and focal length.

Lighting

Adjustable LED backlight with dimmer control alleviates eye strain and improves readability of images.

Electronic Height & Tilt

Easy electronic adjustment of the work surface height and tilt. Digital readout for desk height with four memory presets. This enables every user to preserve optimal settings.

Data & Power Ports

Pop-up units include Ethernet network and parallel ports, as well as standard AC power outlets. Separate USB hubs include four ports.



Soundproofing

Acoustical partitions help to cut down on the background noise and improve concentration.

Cooling System

Monitors and CPU generate a lot of heat. Dissipate it quickly with the advanced environmental control system.

Work Surface Shapes for Single Level Desks

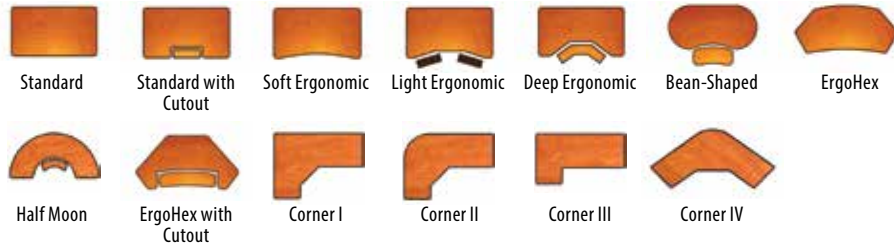

Work Surface Shapes for Double Level Desks



Sample Configurations of Single and Double Level Desks

A. Ergo Tier™ TS 60"W x 30"W:

- Independent electronic height adjustment of work surface and monitors
- Monitor shelf on telescopic drives with a 12-inch upward stroke
- 3-outlet power strip
- Desk-mount CPU holder # CPU-01



B. Ergo Tier™ SW 60"W x 30"D:

- Independent electronic height adjustment of work surface and monitors
- 10"-high slatwall on telescopic drives with a 12-inch upward stroke
- Two Z-series monitor arms #AFCZ666-01
- Two Z-series monitor arms #AFCZ566-01 on 20" vertical track
- LED task light # TAL400
- Pop-up data port & USB hub
- Two desk-mount CPU holders # CPU-01



C. Ergo Tier™ EFX 60"W x 34"D:

- Electronic adjustment of work surface height
- Electronic adjustment of monitor height and focal length
- Monitor platform on telescopic drives for four monitors
- Adjustable CPU holder # CPU 13-25
- Two wire managers # WMF200



NEW

D. Dual Tier™ 72"W x 72"D:

- Independent electronic height adjustment of both tiers
- Two Z-series monitor arms # AFCZ566-02
- Two wire managers # WMF100
- Full bottom shelf



E. Single Tier™ 60"W x 36"D:

- Electronic height adjustment of work surface
- Three clamp-mount Z-series monitor arms # AFCZ566-01
- Adjustable CPU holder # CPU 13-25



F. Single Tier™ 60"W x 36"D:

- Electronic height adjustment of work surface
- Three Z-series monitor arms # AFCZ566-01 on 56" track on three poles
- Swinglift keyboard arm # KA7001
- Full bottom shelf with foot rest # FR010
- 4-inch casters # CAS-4



LCD Monitor Arms/holders

Desktop Series

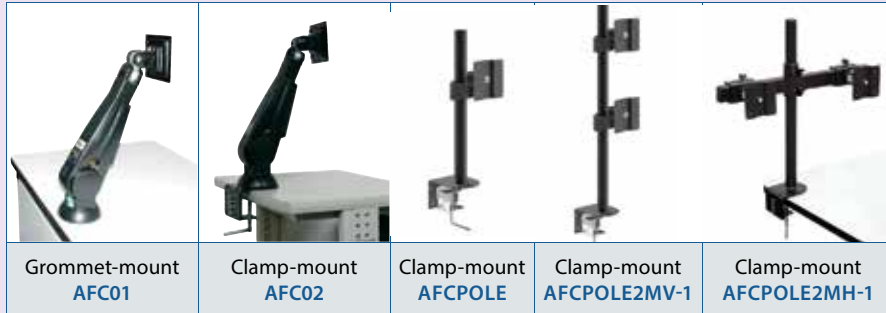

Z-Series



Wall Mount Series

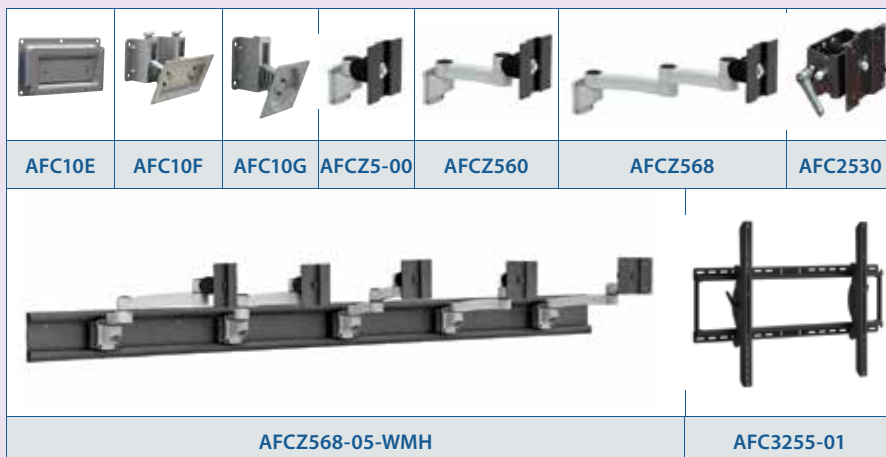

Ceiling Mount Series



CPU Holders

Desk- or wall-mount	
CPU 13-25	CPU-09
Wall-mount CPU-CS909	Wall-mount CPU-919
Wall-mount CPU-102	Wall-mount CPU-101

Lighting

LED Task Light TAL400	
Task Light TAL200A	AmbiTask Light Combo AMBL001
LED Backlight TAL500	

Cable Management & Power Solutions

Length: 12", 24", 36"		Diameter: 1/2"	
Cable Manager WM201		Cable Wrap WM-400	Retractable Power Cord RPC-101
A - 1 1/2"W x 1"H	Length: 30", 60"		
B - 7/8"W x 1/2"H			
Cable Manager WM100	Wire Managers WMF100 and WMF200	Portable AC Power System PS-TL-1	Data & Power Ports DPA-01

More Accessories

Retractable Mouse Tray	Ergonomic shape	Swinglift	Retractable	
Keyboard Arm & Tray KA6000 & TR2000	Keyboard Arm & Tray KA6000 & TR3000	Keyboard Arm KA7001	Keyboard Tray KB03	Keyboard Arm & Tray WM-TR-MZ
Antiseptic Wipe Holder AWH100	Biohazard Waste Holder BWH100	Wire Basket WB-100	Cup Holder MCH-100	Mouse Holder M001
Phone Arm TA002	Laptop Arm AFCZ566-01-LWM-01	Air Fan FanR1-100	Ergonomic Foot Rest FR002	Scanner Holder S01

Storage Accessories

30", 36", 48", 60", 72" or 84" wide			
Flipper Cabinet FC	Wood Clipboard Holder CLPHLD-W	One Door Cabinet D0123	
Two Door Cabinet D0124	Mobile Film Box FB-100	Two Door Pedestal with Two Drawers	Mobile Pedestal P2BF16WD
Metal Pedestal P2FF19MF	Wood Pedestal with lock P3BBF19MF	Slatwall	
			Printer Shelf/Rolling Shelf EXSHR META

FREE on-site consultation

At AFC we want to get it right the first time, every time, to create a custom environment for our Customers. That's why we will come to you to ensure we are maximizing your space and that everything is measured up just right. We will work with your team, at no charge to you, from the beginning to the end of your project.

FREE project support

Our team is here to assist you with your vision. We have the experience to help with your project and pride ourselves in going above and beyond to not just meet, but exceed your expectations.

FREE design service

We want to use our many years of experience creating spaces to offer you this advantage and help you go beyond your imagination. With some of the most mechanically advanced products, we will help you achieve your goals, at no additional cost to you.

Customization

AFC can easily customize all products to adapt to your professional and individual requirements. Whether you need help choosing the right components to configure a product or are considering a complete room redesign, our staff is committed to offering you assistance every step of the way.

Outstanding customer support

Our experienced sales and engineering teams are here to walk you through the process from the smallest to largest jobs. Building rapport with our customers is a driving force throughout the relationship and is maintained during the entire project including follow-up.

LATEST TECHNOLOGIES



Antimicrobial paint

AFC offers the added protection of antimicrobial powder-coat finishes on its products to provide protection against a broad spectrum of microorganisms. When applied to mobile carts, wall mounts, and workstations the risk of spreading harmful bacteria and viruses between patients and health care workers is greatly reduced, according to doctors using the antimicrobial powder coating in their hospitals and laboratories.

High-density polyethylene (HDPE) top available with antimicrobial protection

A new kind of antimicrobial protection upgrade is available in many of AFC's polymer sheets, slabs and massive shapes. HDPE helps products stay cleaner between cleanings and inhibits the growth of product-damaging microorganisms, including bacteria, algae and fungi on the surface. Microbe cell walls that come into contact with HDPE are destroyed on contact, without creating opportunities for adaptive or resistant strains to form. Because the antimicrobial agent is bonded at the atomic level throughout the sheet, it will not leach out of the product. This means the agent retains its effectiveness throughout the life of the product and does not harm the environment.

It is safe, non-toxic and non-hazardous to ship and handle. The product is EPA-registered and listed with the FDA as a modifier to medical devices.

Products made using AFC's polymers with HDPE are easy to clean, disinfect and keep hygienic using standard cleaning procedures. Constant use of cleaning solutions will not affect any polymer.

STANDARD COLORS

Laminate

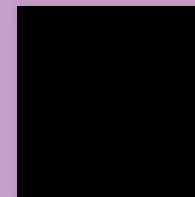

Black



Speckled Gray



Gray



Mahogany



Wild Cherry



Natural Pear

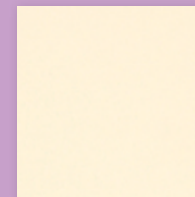

Putty

For any other color call us at 1.800.663.3412

Frame



Black



Gray

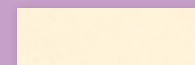

Putty



White

Molding



Black

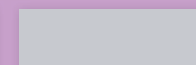

Gray

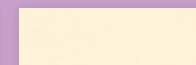

Putty

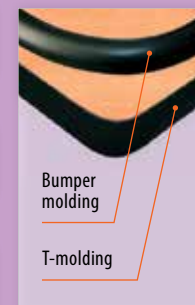

Use our Room Layout Designer to see how you can create an ergonomic environment with AFC's products





13-16 133rd Place • College Point • NY 11356

toll free: 1.800.663.3412
t: 1.718.747.0237
f: 1.718.747.0726
www.afcindustries.com

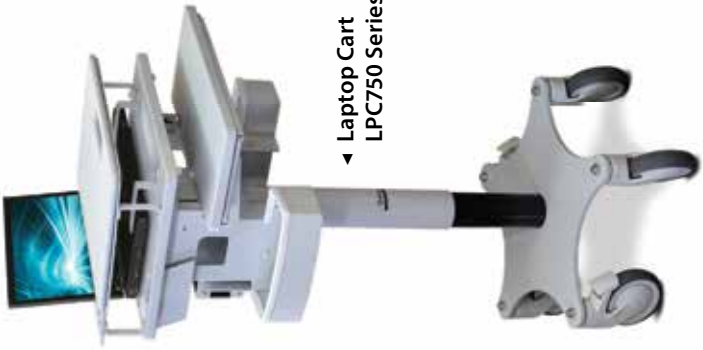

◀ Laptop Cart
LPC750 Series

We deliver our products fully assembled to ensure maximum quality and convenience for our customers.



Scan here with your smart phone to visit our website

