

TOP VIEW

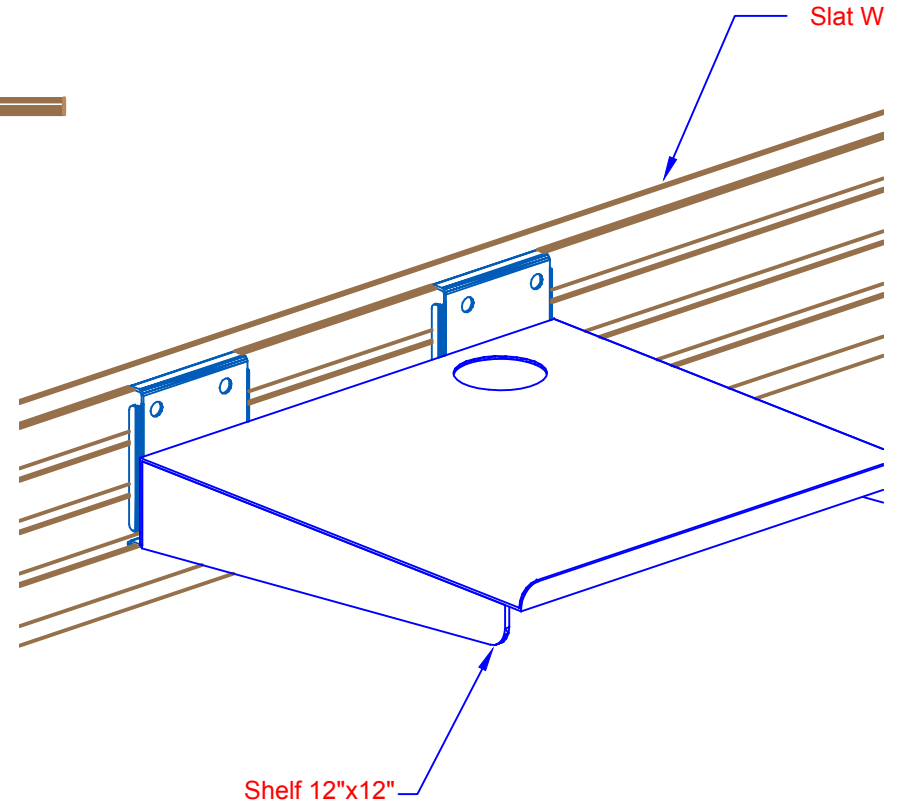

ISOMETRIC VIEW

NOTES :	MATERIAL :	DRAWN BY : BD/YE	DATE: 3/29/19	DESCRIPTION :
	TOLERANCES UNLESS OTHERWISE SPECIFIED	A P P R O V E D		Slat Wall
1) * Monitor holder can hold up to 20 lbs monitor 2) Customer has to attach slat wall to a rigid wall which can hold the weight of equipment	FRACTIONAL ±1/64	ENG :		USED ON :
	2 PLC. DEC. ±.01	MFG :		PATH :
	3 PLC. DEC. ±.001	QA :		\Fin.Assy\Accessories\Slat Wall
ANGULAR ±.5°	FINISH	SCALE: ~ 1-1/2" = 1" - 0"	SHEET : 1 OF 1	PDF NAME: SW42_FZ_Ph_C_01
				RE :