

NOTE:
WM100B Wire Manager to be provided. Location and amount TBD.

** Material 20-24 Ga or greater

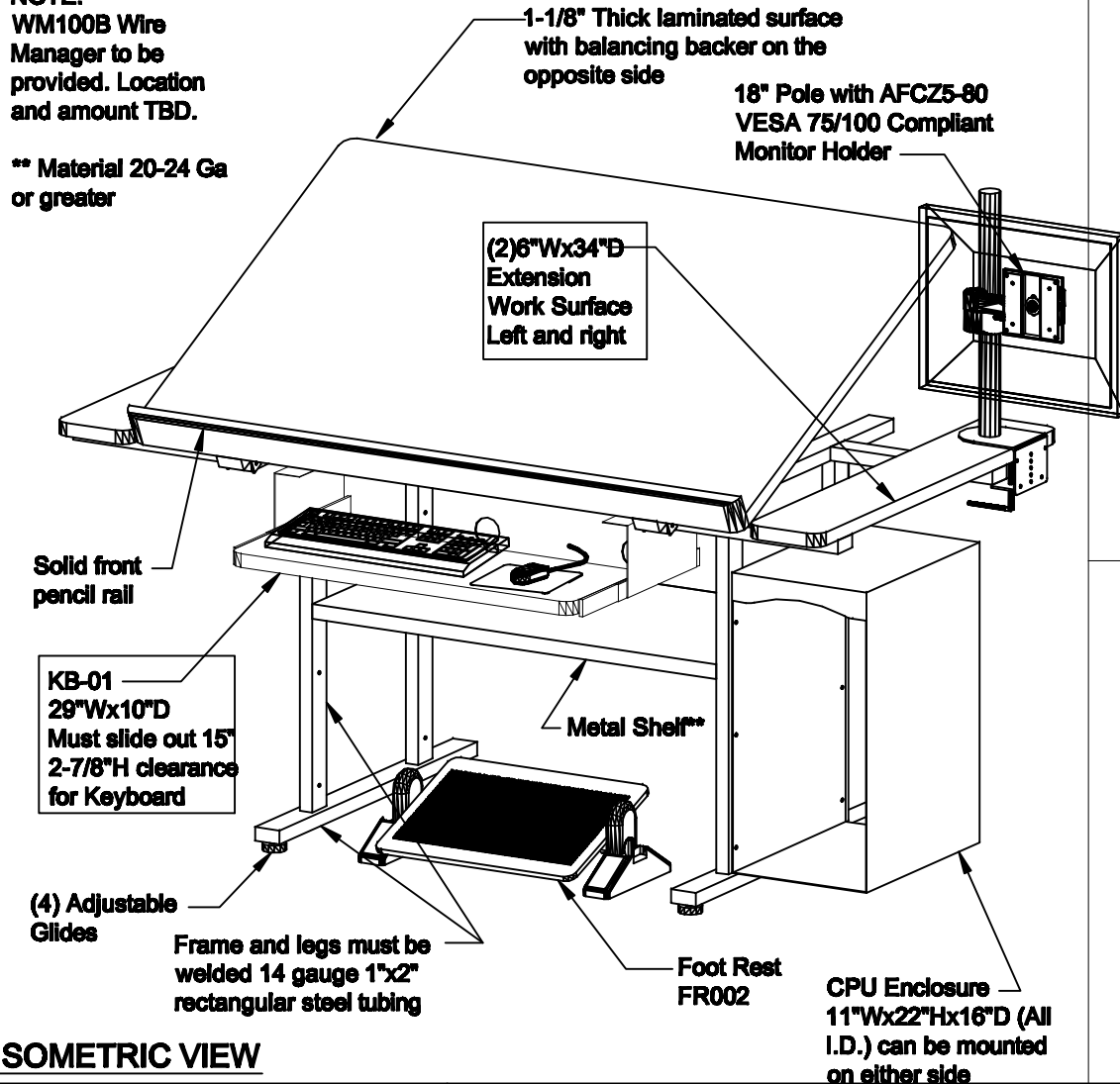

ISOMETRIC VIEW

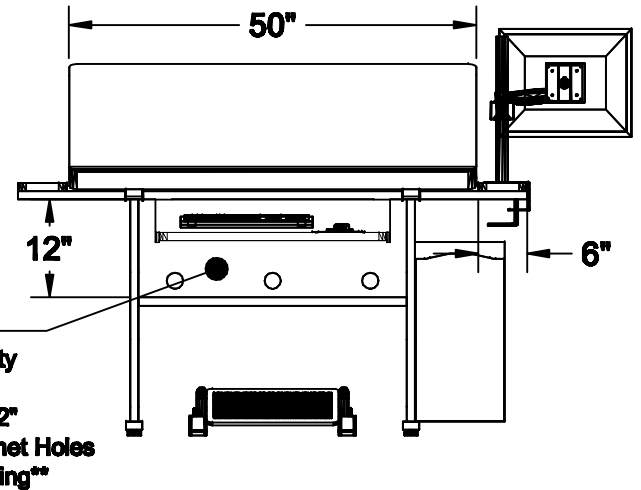

FRONT VIEW

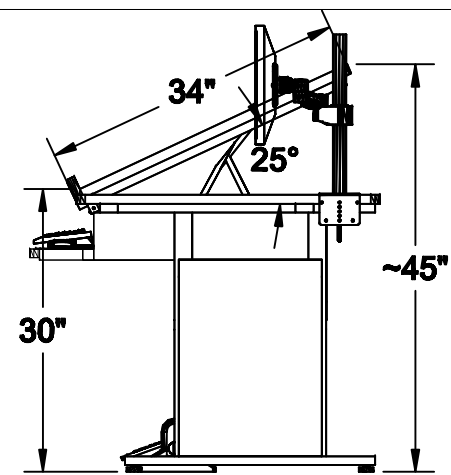

SIDE VIEW

NOTES:

Concept drawing only.
Final design may vary

MATERIAL:

TOLERANCES UNLESS OTHERWISE SPECIFIED
FRACTIONAL ±1/64
2 PLC. DEC. ±.01
3PLC. DEC. ±.001
ANGULAR
FINISH

DRAWN BY: YN

DATE: 2/11/13

DESCRIPTION:

Drafting Table

APPROVED

USED ON:

ENG:

MFG:

QA:

PATH:
F:\Assy\Carts&Racks\Drafting\

PDF NAME:
DFT_5034_FZ_C_Tilt_Wing_01-REV 4

REV: 4
SIZE A

NOT TO SCALE

SHEET: 1 OF 1