

**TOP VIEW**

**TOP VIEW showing all size cassettes**

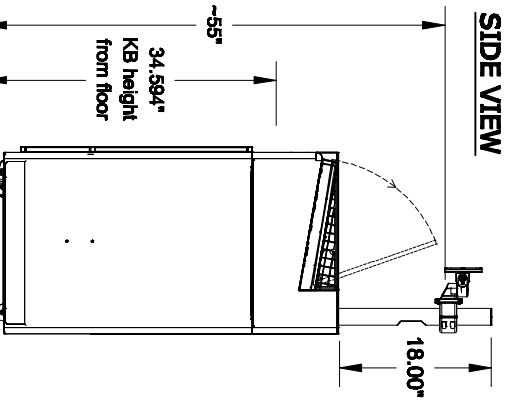

**SIDE VIEW**

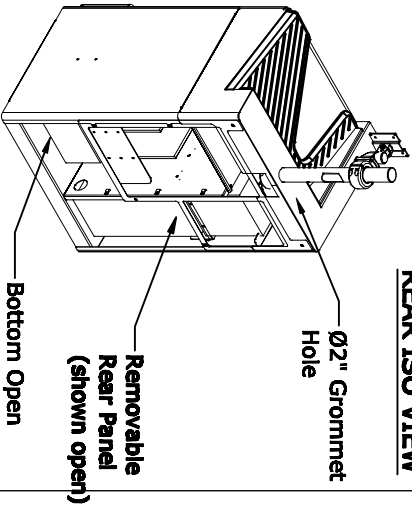

**REAR ISO VIEW**

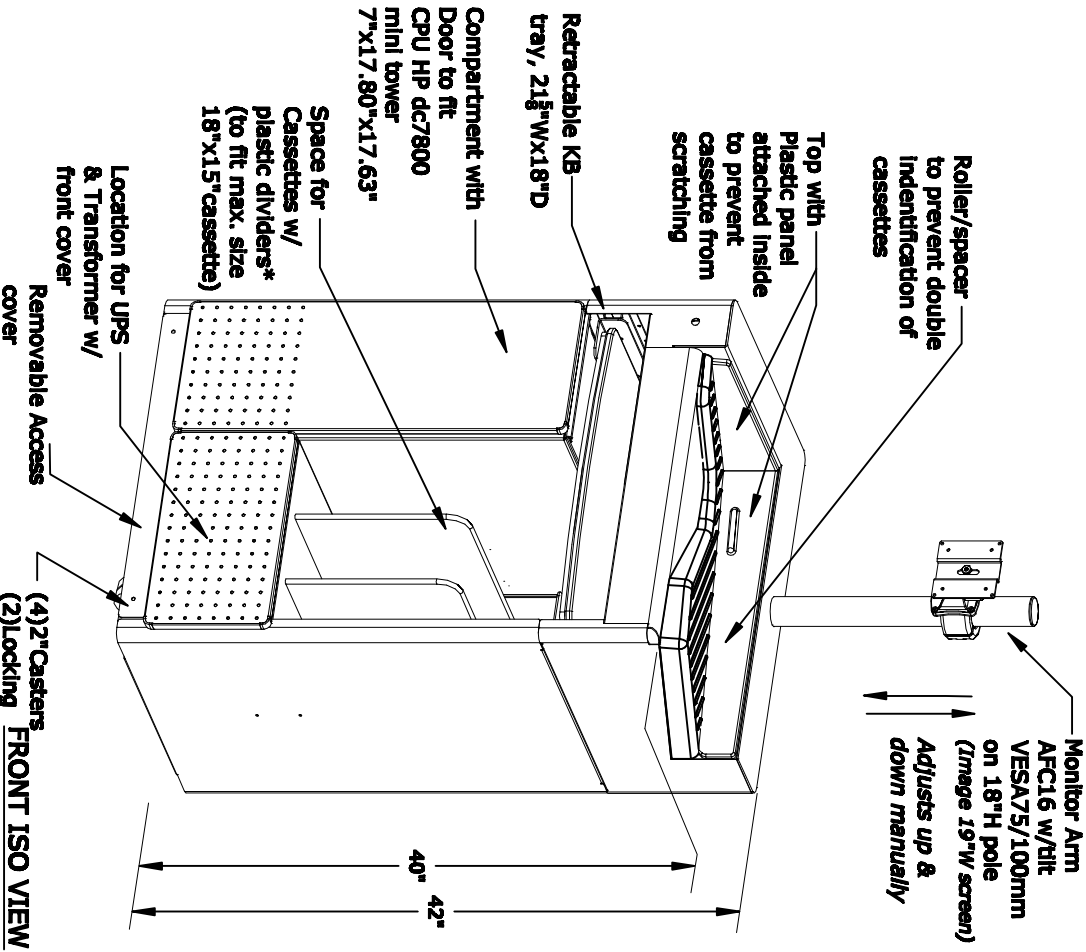

**FRONT ISO VIEW**

NOTES:

- All edges & corners to be round.
- Space b/w door and KB tray minimized
- No screws used to prevent scratching of cassettes

MATERIAL:

TOLERANCES UNLESS OTHERWISE SPECIFIED For Linear & angular dimensions ±1/4"

**DRAWN BY : PR/GM**

A P P R O V E D

**DATE: 09-22-13**

DESCRIPTION :

ENG :

USED ON :

MFG :

PATH :

QA :

PDF NAME:

SCALE : N.T.S.

SHEET : 1 OF 1

**AGDM-262140-08**

REV. SIZE  
20